



## Revista Internacional de Investigación e Innovación Tecnológica

Página principal: [www.riit.com.mx](http://www.riit.com.mx)

**A versatile educational tool to detect adulterated honey with Arduino and Python-OpenCv**

**Una herramienta educativa versátil para detectar Miel adulterada con Arduino y Python-OpenCv**

**Sifuentes-Gallardo, C.<sup>a</sup>, Hernández-Ortiz, M.<sup>a</sup>, Ortega-Sigala, J.<sup>a</sup>, Rodríguez-González, B.<sup>a</sup>, Cardoso-Pérez, M.<sup>a</sup>, Esquivel-Félix, R.<sup>b</sup>, Guirette-Barbosa, O.<sup>c</sup>, Cruz-Domínguez, O.<sup>c\*</sup>, Durán-Muñoz, H.<sup>a\*</sup>**

<sup>a</sup> Universidad Autónoma de Zacatecas, Jardín Juárez 147, Zacatecas Centro, 98000.

<sup>b</sup> Universidad Tecnológica del Estado de Zacatecas, Ejido, Cieneguitas, Zac.

<sup>c</sup> Universidad Politécnica de Zacatecas, Plan de Pardillo, 99059 Fresnillo, México.

[clausifuen@uaz.edu.mx](mailto:clausifuen@uaz.edu.mx); [mar\\_h2o@hotmail.com](mailto:mar_h2o@hotmail.com); [jjosila@fisica.uaz.edu.mx](mailto:jjosila@fisica.uaz.edu.mx); [brodriguez@upz.edu.mx](mailto:brodriguez@upz.edu.mx);  
[mcardoso\\_63p@yahoo.com.mx](mailto:mcardoso_63p@yahoo.com.mx); [resquivel@utzac.edu.mx](mailto:resquivel@utzac.edu.mx); [omarguirette@hotmail.com](mailto:omarguirette@hotmail.com); [ocruz@upz.edu.mx](mailto:ocruz@upz.edu.mx)\*;  
[hectorduranm@hotmail.com](mailto:hectorduranm@hotmail.com)\*

**Technological innovation:** Development of a low-cost system to detect adulterated honey.

**Industrial application area:** Identification of adulterated honey samples.

Received: may 11th, 2023

Accepted: february 13th, 2024

### Resumen

La miel adulterada es un grave problema mundial, y detectarla en las zonas rurales es aún más complicado. Debido a falta de disponibilidad de equipo de laboratorio para analizar la miel adulterada. Además, las pruebas de laboratorio son muy costosas y las personas de las regiones rurales no pueden pagar sus altos costos. Para solucionar este problema, el objetivo de este trabajo fue implementar dos herramientas prácticas para detectar miel adulterada mediante el uso de un dispositivo electrónico de bajo costo basado en Arduino y mediante Python-OpenCv. Este trabajo se enfoca en hacer que ambas herramientas sean de fácil acceso para los productores de miel, quienes son mayormente afectados ante este grave problema. La novedad de este trabajo es mostrar una metodología amigable para implementar ambas herramientas, la cual puede ser fácilmente reproducida por pobladores de regiones rurales sin conocimientos profundos en electrónica y programación. En este trabajo se encontró evidencia de adulteración de miel. Finalmente, el costo de ambas herramientas es 10 veces menor que los equipos comerciales para el análisis de muestras de miel adulterada.

**Palabras clave:** Regiones rurales, OpenCv, Python, Arduino.

## Abstract

Detecting adulterated honey poses a significant global challenge, especially in rural areas where access to laboratory equipment is limited. The expense associated with laboratory tests further compounds the issue, rendering them unaffordable for many rural inhabitants. In response, this study aims to introduce two practical tools for detecting adulterated honey using a low-cost electronic device based on Arduino and Python-OpenCV. The primary objective is to make these tools accessible to honey producers, who bear the brunt of this problem. The innovation lies in the user-friendly methodology employed, designed to be easily replicated by individuals in rural areas with minimal expertise in electronics and programming. The study revealed evidence of honey adulteration, underscoring the urgency of such solutions. Importantly, both tools are ten times cheaper than commercial equipment typically used for honey analysis, promising a cost-effective approach to addressing this pressing issue.

**Keywords:** Rural regions, OpenCv, Python, Arduino.

## 1 Introduction

Honey is derived from the carbohydrate-rich secretions of plants, primarily nectar and honeydew. Nectar, sourced from plant lymph, contrasts with honeydew, a secretion produced by parasitic insects using plant lymph [1]. Essentially, honey represents a naturally occurring, supersaturated solution of sugars, with fructose and glucose being the predominant monosaccharides. It is further categorized into mono-floral and multi-floral varieties [2]. Mono-floral honey, comprising pollen grains from a single plant species, offers distinctive biological properties appealing to consumers [3]. In contrast, multi-floral honey originates from diverse plant sources, lacking a predominant floral origin [4].

Honey serves as a valuable food resource, finding its way into countless culinary creations and boasting a plethora of applications [5]. Its versatility extends beyond the kitchen, as honey has been employed in the treatment of skin wounds and gastrointestinal ailments [6]. This therapeutic efficacy is attributed to its inherent antibacterial and anti-inflammatory properties, stemming from its high

osmolarity, acidity, and rich content of hydrogen peroxide and non-peroxide components [7]. Moreover, the bioactivity of honey finds utilization in both traditional and contemporary apitherapy practices, highlighting its significance beyond mere sustenance.

However, a concerning trend has emerged with the proliferation of adulterated honey globally, spurred by decreased production and consequent elevated prices. This economic landscape renders honey adulteration increasingly appealing to illicit producers, thereby compromising its quality [8]. Such nefarious practices not only diminish the nutritional value of honey by depleting its vitamin and enzyme content but also present a growing challenge in detection. As adulteration techniques evolve in complexity and sophistication, distinguishing adulterated honey from its authentic counterpart becomes progressively arduous. Adulteration can be categorized into two main groups: direct, involving the addition of substances to honey, and indirect, where bees are fed adulterated substances [9].

Direct adulteration involves the addition of substances directly to honey and can be categorized into four main aspects: sugar addition, water content, processing, and origin. Indirect adulteration occurs when bees are fed adulterated substances [8, 9]. However, the most prevalent methods of honey adulteration include the addition of sucrose or the overfeeding of bees with sugar and other sucrose types [10]. Consequently, there is an urgent need to develop effective techniques for detecting honey adulteration [11].

The issue of honey adulteration is particularly acute in rural regions, where the bulk of honey production occurs globally. In these areas, honey is frequently adulterated with industrial sugar, chemicals, and water, either directly or indirectly [12]. Compounding this challenge, laboratory tests for honey adulteration are prohibitively expensive for rural inhabitants, further exacerbating the problem.

Various methodologies have been proposed in literature to detect honey adulteration. For instance, in an effort to mitigate fraudulent practices, the Codex stipulates that honey should not contain any food ingredients or additives, nor should other substances be added [13]. However, this criterion may not always be entirely reliable due to the inherent variability in honey composition, influenced by factors such as botanical origin, bee species, geographical location, season, and storage conditions [14]. Consequently, a myriad of strategies and techniques have been developed to characterize and authenticate honey, reflecting its complex nature [15]. These methods encompass a range of approaches including physicochemical analysis, microscopy, chromatography, immunoassays, thixotropy, DNA metabarcoding, carbon isotope analysis, sensor technologies, and spectroscopy.

Specifically, assessing the water content in honey, a crucial determinant of its quality, can be achieved through refractive index (RI) measurements using an Abbe-type refractometer. Fiber optic detection has emerged as a successful method for identifying adulterated honey [16]. Additionally, devices such as the Hanna Honey Color 221 colorimeter enable the determination of honey concentration based on its color. However, the high cost of such equipment renders it inaccessible to rural populations [17]. Furthermore, in the event of equipment breakdown, repair or compliance with ISO standards becomes challenging in rural areas. Consequently, these techniques and devices remain impractical for implementation in regions lacking adequate laboratory infrastructure for honey analysis.

Thus, this study proposes the implementation of two tools for rapid and straightforward detection of adulterated honey. The first tool utilizes OpenCV-Python for computational analysis, while the second tool is built upon the Arduino data acquisition board, known for its efficacy in developing low-cost laboratory equipment [18, 19]. The innovation lies in creating two reproducible tools accessible to rural residents, offering a cost-effective alternative to commercial equipment. This work introduces a user-friendly methodology to facilitate the replication of both tools by individuals in rural areas. Crucially, the focus extends beyond mere accessibility, aiming to make these tools readily available to honey producers and institutions invested in ensuring product quality within rural regions.

## 2 Materials and methods

This section outlines a methodology for rapidly assessing the purity of honey samples using two cost-effective tools. These tools are designed to be accessible to users with limited expertise in electronics and programming. The first tool is an Arduino-based electronic device, while the second utilizes Python-OpenCV for image processing. Notably, calibration of both tools does not require additional chemical elements and can be performed using honey samples from the same region. This regional calibration is particularly beneficial in rural areas where access to sophisticated analysis tools and standardized color references may be limited. As such, the methodology emphasizes practical, simple sample preparation using locally sourced honey samples to ensure accurate results across diverse honey varieties and geographical regions.

### 2.1 Preparation of honey samples

The sample preparation process began with the acquisition of multiflora honey directly from a honeycomb sourced from a rural region. Subsequently, five samples were meticulously prepared in 3 ml cuvettes. These samples were calibrated to varying concentrations to facilitate the calibration process of the electronic device. The concentrations used for calibration were categorized as follows: c1) 0% Honey-100% H<sub>2</sub>O; c2) 25% Honey-75% H<sub>2</sub>O; c3) 50% Honey-50% H<sub>2</sub>O; c4) 75% Honey-25% H<sub>2</sub>O; c5) 100% Honey-0% H<sub>2</sub>O. Following the calibration, a distinct sample of honey labeled "sa" was extracted from the same region to ascertain its purity. The honey samples spanning different concentrations, alongside the sample collected from the region, are depicted in Figure 1.

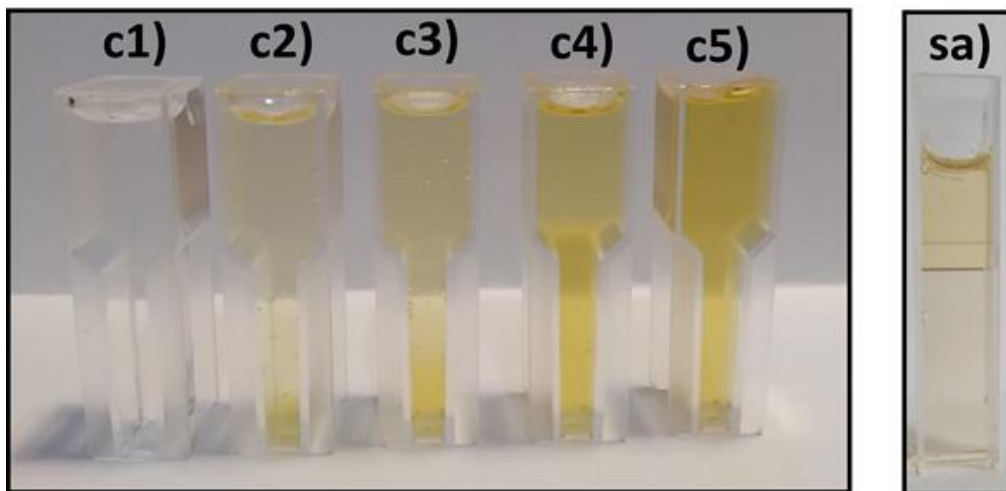

**Figure 1.** Honey samples with concentrations of: c1) 0% Honey-100 % H<sub>2</sub>O; c2) 25% Honey-75% H<sub>2</sub>O; c3) 50% Honey-50% H<sub>2</sub>O; c4) 75% Honey-25% H<sub>2</sub>O; c5) 100% Honey-0% H<sub>2</sub>O. Sample honey labeled "sa".

### 2.2 Arduino based electronic device

The device illustrated in Figure 2 is designed to electronically assess the integrity of a honey sample for potential adulteration. The process initiates with the activation of the RGB LED (Figure 2-g), emitting light at a specific wavelength (Figure 2-p). This

emitted light passes through the cuvette containing the honey sample (Figure 2-m-n). Subsequently, any absorption of the light by the honey (Figure 2-q) is swiftly detected by the photoresistor (Figure 2-f). The ensuing electrical signal undergoes amplification through the LM324 circuit (Figure 2-i) and is

then processed by the Atmega-328P microcontroller (Figure 2-c), often referred to as the device's "brain." This microcontroller meticulously analyzes the signals from the RGB LED and computes the concentration of the honey sample (represented as "sa"). The

calculated concentration is promptly showcased on the LCD screen (Figure 2-b). Moreover, the acquired data can be conveniently stored on the SD card (Figure 2-a) for subsequent retrieval and in-depth analysis on a computer.

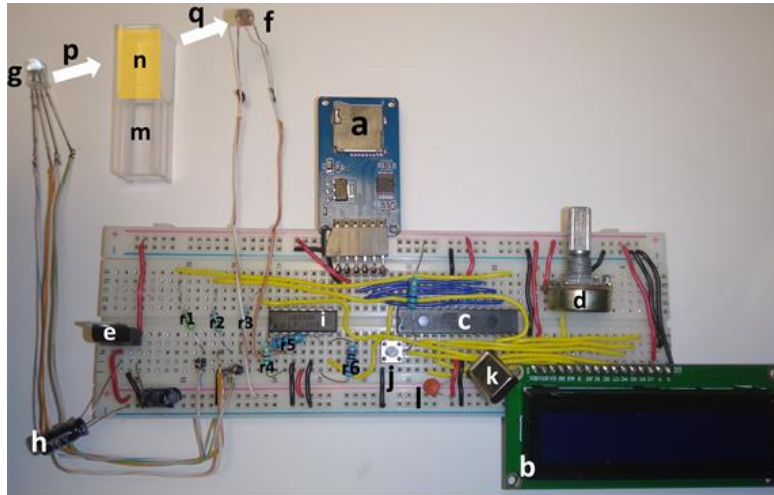

**Figure 2.** Electronic device configuration. a) MicroSD memory module, b) LCD screen, c) Atmega328P microcontroller, d) Precision resistance, e) Voltage controller, f) Photo-resistance, g) RGB LED, h) Capacitor, i) LM324 circuit, j) Push-button, k) 16MHz quartz crystal, l) 22pF ceramic capacitor, p) Wavelength emitted by the RGB Led, m) Cuvette, n) honey, q) resulting wavelength.

Figure 3 provides a comprehensive electronic diagram of the device, catering to residents of rural areas lacking extensive expertise in electronics and programming, facilitating easy replication of the electronic setup. Positioned between the RGB LED (Figure 3-

g) and the photoresistor (Figure 3-f) lies the cuvette containing honey. Notably, the electronic device incorporates an MC7805 voltage controller (Figure 3-e) to regulate voltage levels effectively.

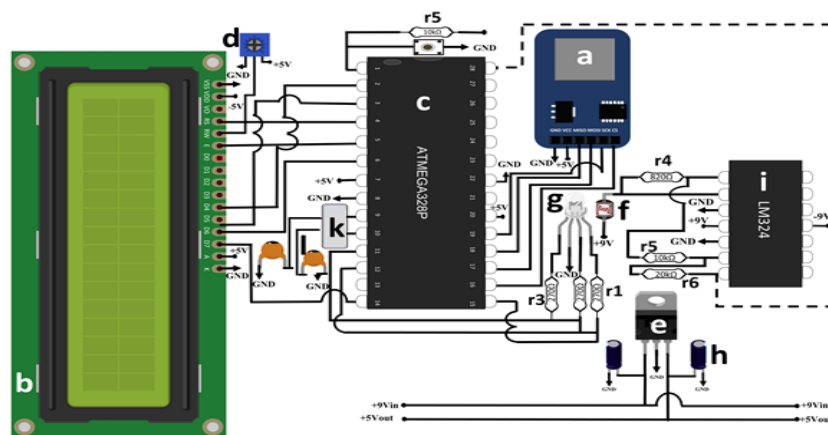

**Figure 3.** Electronic diagram of the device. a) MicroSD memory module, b) LCD screen, c) Atmega328P Microcontroller, d) Precision resistance, e) MC7805 Voltage Controller, f) Photo resistance, g) RGB LED, i) LM324 circuit, l) 22pF ceramic capacitor, k) 16MHz quartz crystal, r3-r1) Resistance 270 ohms, r5) 10k ohms, r6) 20k ohms, r4) 820 ohms.

The programming code used in the Atmega-328P microcontroller is shown in Figure 4.

Each programming line has a description of the function it performs.

<pre>#include &lt;LiquidCrystal.h&gt; // Liquid crystal display library #include &lt;SPI.h&gt;           // SPI interface LIBRARY #include &lt;SD.h&gt;           // SD card library #define SSpin 10         // Slave select digital pin 10 int redPin= 5;          //RGB connections int greenPin = 6; int bluePin = 9; int i=1;               // Counter for data organization in sd memory int valor;             // Variables for voltage conversion float voltaje; const int rs = 2, en = 3, d4 = 0, d5 = 1, d6 = 4, d7 = 7; // LCD connections LiquidCrystal lcd(rs, en, d4, d5, d6, d7); File archivo; // Object of type file void setup() {   pinMode(redPin, OUTPUT);   pinMode(greenPin, OUTPUT);   pinMode(bluePin, OUTPUT);   lcd.begin(16, 2);           //LDC (16x2) is initialized   if (!SD.begin(SSpin)) {    // Sd memory is checked     return; }   archivo = SD.open("prueba.txt", FILE_WRITE); // Open for reading/writing prueba.txt file   archivo.close(); } void loop() { if(SD.exists("prueba.txt")){   // Verify that the file "prueba.txt" exists   while(1){      // Samples are taken for an infinite time     archivo = SD.open("prueba.txt", FILE_WRITE); // Open for reading/writing prueba.txt file</pre>	<pre>if (archivo){   // The label "Muestra 'i'" is saved in the .txt file   archivo.println(" ");   archivo.print("Muestra: ");   archivo.println(i);   archivo.close(); }   setColor(0, 0, 255); // The wavelength to be sampled is set   lcd.clear();           // LCD messages   lcd.setCursor(0,0);   lcd.print("LECTURA VOLTAJE:");   lcd.setCursor(0,1);   lcd.print("AZUL: ");   delay(1500);   valor = analogRead(A5); // Analog voltage reading   voltaje = valor*(5.0/1023.0); // Voltage conversion   lcd.print(voltaje); // Voltage value is printed on LCD   archivo = SD.open("prueba.txt", FILE_WRITE); // Open for reading / writing test.txt file   if (archivo){     archivo.print("Voltaje color azul: "); // The label "Voltaje color azul" is saved in the .txt file     archivo.println(voltaje); // voltage value saved in the .txt file     archivo.close();   }   delay(7000);   i=i+1; //Counter is incremented to indicate the next sample }}} void setColor(int redValue, int greenValue, int blueValue) { //Function for changing wavelength of light   analogWrite(redPin, redValue);   analogWrite(greenPin, greenValue);   analogWrite(bluePin, blueValue);</pre>
--	---

**Figure 4.** Programming code used in the Atmega-328P microcontroller.

The cost of commercially available honey adulteration testing devices is prohibitively high. Conversely, the electronic device proposed in this study presents a solution at a mere fraction of the cost, approximately one-

tenth that of commercial equipment. Table 1 outlines the electronic components utilized in the device, supplemented with the cost of each component for clarity and transparency.

**Table 1.** Total cost of the device and each electronic component.

Component	Cost [Dollars]
16MHz quartz crystal, (2) 22pF ceramic capacitor, (3) 270Ω resistance, 10kΩ precision potentiometer, L7805 voltage regulator, Photoresist, RGB LED.	\$ 5.00
16x2 LCD Display	\$ 3.00
LM324 circuit	\$ 4.00
ATmega328P Microcontroller	\$ 3.00
MicroSD memory module	\$ 3.00
Total Cost	\$ 18.00

The qualitative analysis of honey samples in this study relies on the fundamental principle of Beer-Lambert's law. This principle, established by the pioneering work of August Beer and Johann Lambert, elucidates that the intensity of light exiting a medium (I) diminishes exponentially in relation to either

concentration (Beer) or path length (Lambert), compared to the intensity of light entering the medium ( $I_0$ ). Often amalgamated, Beer's and Lambert's relationships are typically expressed in a unified logarithmic equation, as demonstrated by equation 1 [11].

$$A = \epsilon b C = -\log T = -\log\left(\frac{I}{I_0}\right) = -\log\left(\frac{V_{\text{sample}} - V_{\text{dark}}}{V_{\text{water}} - V_{\text{dark}}}\right) \quad (\text{Eq. 1})$$

In this context, the ratio of I to  $I_0$  represents the transmittance (T), while A denotes the absorbance of the medium. Initially, a measurement of the "dark" voltage ( $V_{\text{dark}}$ ) was obtained with the LED unlit, serving as a baseline. Subsequently, a voltage measurement corresponding to essentially 100% transmittance ( $V_{\text{water}}$ ) was recorded with the LED activated. Finally, the voltage across each varying honey concentration was meticulously documented upon the addition of colored test solution ( $V_{\text{sample}}$ ).

### 2.3 Computational tool based on Python-OpenCv

The characterization of honey samples based on their concentration was conducted using a computational tool built upon Python-OpenCv. This tool operates on the principle of image processing and has been developed using Python, leveraging OpenCv libraries for image manipulation, Numpy for efficient

handling of matrices, and Matplotlib for generating graphs and histograms. The Python program, essential for this analysis, is freely downloadable from the official Python website:

<https://www.python.org/downloads/>. To install OpenCv, simply execute the command "pip install opencv-python" in the command console (Figure 5-a). Subsequently, the honey samples were analyzed based on the histograms generated from each honey cuvette. To enable this functionality, the Matplotlib package must be installed using the command "pip install matplotlib" (Figure 5-b). Alternatively, Windows Notepad or text files (with .txt extension) can be utilized to create and store Python programs. These programs should be saved with a .py extension. To execute the program for sample characterization, navigate to the command console, select the folder containing the program, and enter the program's name followed by the .py extension (Figure 5-c).

```
a) C:\Users\Héctor Duran>pip install opencv-python
```

```
b) C:\>pip install matplotlib
```

```
c) C:\Users\fermi\Desktop\python>python eje4.py
```

**Figure 5.** a) OpenCV-Python installation. b) Matplotlib installation. c) Running a program from the command console.

A photograph was captured for each honey sample, which was subsequently associated with a histogram using Python-OpenCv. To derive the histograms for each honey sample, the program depicted in Figure 6-a was executed. Each line of code in the program is accompanied by a comment explaining its functionality. Following the determination of histograms for each sample (c1, c2, c3, c4, c5,

and sa), a correlation matrix is generated. This matrix enables the identification of the honey sample with the highest correlation to the reference sample "sa." Once the sample with the strongest correlation is identified, its concentration level can be determined, facilitating the detection of adulteration if present. The program utilized to generate the correlation matrix is illustrated in Figure 6-b.

a)	b)
<pre>import cv2 #Import OpenCv library for first histogram shape import numpy as np #Numpy library import for array management from matplotlib import pyplot as plt #Matplot library import for second histogram shape def run():     #Image reading     img = cv2.imread("sample1.jpg", cv2.IMREAD_GRAYSCALE)     cv2.imshow('Original Image', img)     #alcHist command to create histogram and save it to a variable     hist = cv2.calcHist([img], [0], None, [256], [0, 256])     #Creation of figure to display images on screen.     #ax is for the location of the image within the figure     fig, ax = plt.subplots(2, 2)     ax[0, 0].imshow(img, cmap='gray')     ax[0, 0].set_title('Imagen')     ax[0, 0].axis('off')     ax[0, 1].plot(hist, color='gray')     ax[1, 0].imshow(img, cmap='gray')     ax[1, 0].set_title('Imagen')     ax[1, 0].axis('off')     #Sample and histogram creation with Matplot library     ax[1, 1].hist(img.ravel(), 256, [0, 256])     plt.show() #Show figure     cv2.waitKey(0) #Time function to not close the window. if __name__ == '__main__':     run()</pre>	<pre>import pandas as pd import matplotlib.pyplot as plt %matplotlib inline import numpy as np import seaborn as sns contamina=pd.read_csv('data2.csv') contamina_corr=contamina.corr(method='spearman') contamina_corr</pre>

**Figure 6.** a) Program to find the histograms of each sample with different concentrations of honey. b) Programming code to generate the correlation matrix.

### 3 Results and Discussion

#### 3.1 Sample characterization using Arduino

For calibrating the Arduino-based electronic device, five samples comprising various

concentrations of honey and H<sub>2</sub>O were synthesized. These samples were then subjected to optical stimulation using an RGB LED, with maximum luminescent peaks at

460 nm, 525 nm, and 625 nm. Each sample underwent three tests to assess the device's margin of error and ascertain its reliability. Figure 7-a illustrates the absorbance results of the five samples with concentrations as follows: c1: 0% Honey-100% H<sub>2</sub>O; c2: 25%

Honey-75% H<sub>2</sub>O; c3: 50% Honey-50% H<sub>2</sub>O; c4: 75% Honey-25% H<sub>2</sub>O; c5: 100% Honey-0% H<sub>2</sub>O. Notably, Figure 7-a demonstrates that the coefficient R<sup>2</sup> approaches unity, indicating high correlation and reliability in the device's performance.

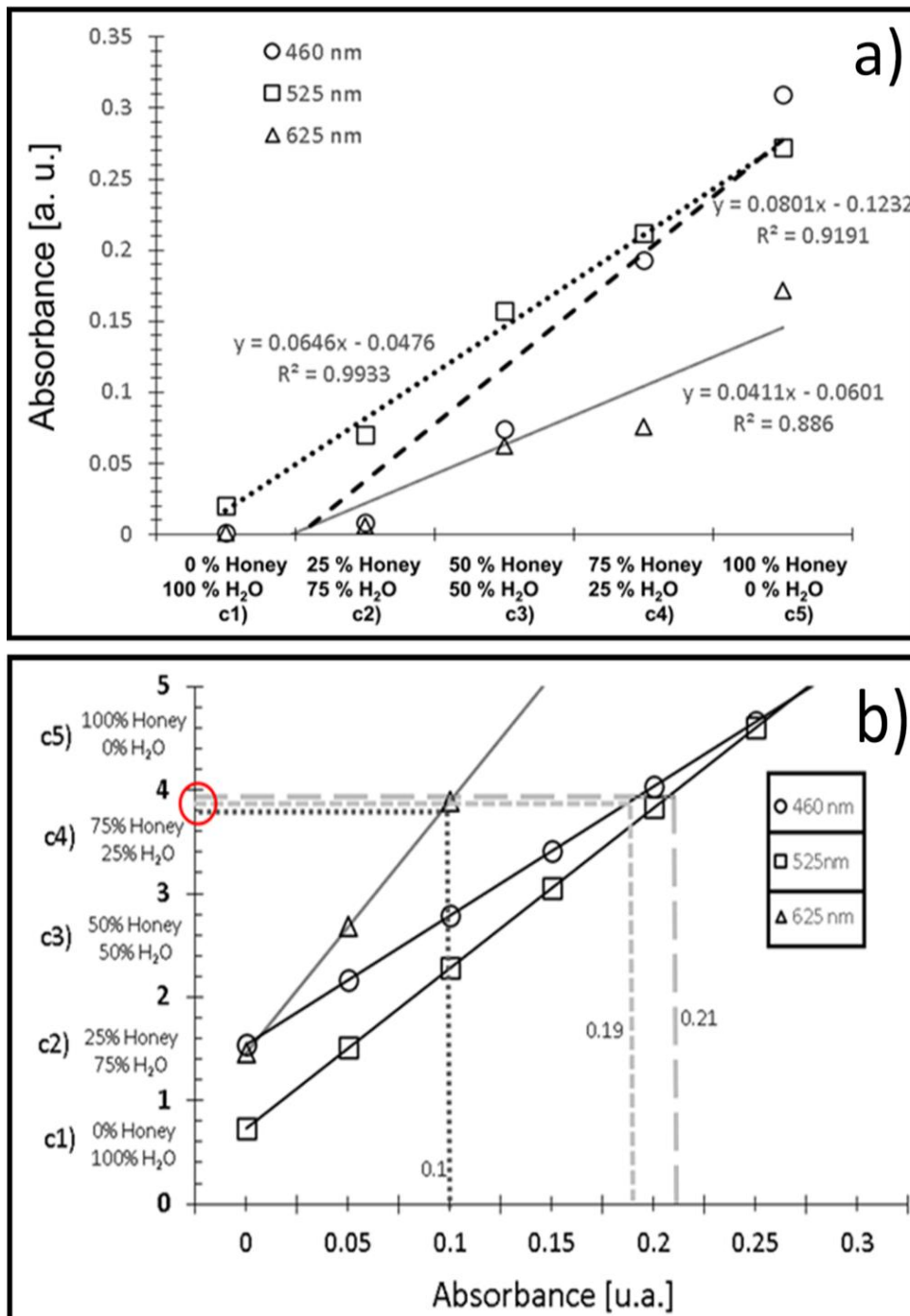

**Figure 7.** a) Absorbance of samples with different concentrations of Honey-H<sub>2</sub>O. b) Graph to determine the concentration range of honey.

Therefore, the fit model used has an acceptable approximation to the variability of the device response. It was found that the fitting equations to find the absorbance of the sample "sa" are as follows:

$$460 \text{ nm} \rightarrow \text{absorbance} = 0.0801 \text{ concen} - 0.1232 \quad (\text{Eq. 3.1})$$

$$525 \text{ nm} \rightarrow \text{absorbance} = 0.0646 \text{ concen} - 0.0476 \quad (\text{Eq. 3.2})$$

$$625 \text{ nm} \rightarrow \text{absorbance} = 0.0411 \text{ concen} - 0.0601 \quad (\text{Eq. 3.3})$$

In this study, it was observed that the device exhibits a superior absorbance response at a wavelength of 460 nm. Furthermore, by determining the absorbance value through equations 3.1 - 3.3, the concentration level of the sample "sa" can be determined. Additionally, equations 3.4 - 3.6 enable the determination of the concentration level of a sample from the region based on the absorbance coefficient obtained by the electronic device proposed in this study.

$$460 \text{ nm} \rightarrow \text{concen} = (\text{absorbance} + 0.1232) / (.0801) \quad (\text{Eq. 3.4})$$

$$525 \text{ nm} \rightarrow \text{concen} = (\text{absorbance} + 0.0476) / (0.064) \quad (\text{Eq. 3.5})$$

$$625 \text{ nm} \rightarrow \text{concen} = (\text{absorbance} + 0.0601) / (0.041) \quad (\text{Eq. 3.6})$$

After calibrating the electronic device, we determined the absorbance values of a sample labeled as 'sa' using wavelengths of 460 nm, 525 nm, and 625 nm. The obtained absorbance values were 0.19, 0.21, and 0.1, respectively, for each wavelength. These values were then used in equations 3.4-3.6 to establish the honey concentration range of the sample 'sa.' Figure 7-b illustrates that the honey concentration range is 75% Honey – 25% H<sub>2</sub>O. Interestingly, all three different wavelengths yield the same concentration range in honey (indicated by the red circle). The absorbance values obtained from the sample 'sa' at these three wavelengths are summarized in Table 2.

**Table 2.** Absorbance values of the sample "sa".

Wavelength	Absorbance	Honey Concentration Range value	Honey Concentration Range
460 nm	0.19	3.91	75% Honey - 25% H <sub>2</sub> O
525 nm	0.21	3.98	75% Honey - 25% H <sub>2</sub> O
625 nm	0.1	3.89	75% Honey - 25% H <sub>2</sub> O

### 3.2 Characterization of the samples using the computational tool

The histograms associated with each sample (c1, c2, c3, c4, c5, and "sa") are presented in

Figure 8. The purpose of this method is to compare the histogram of the sample "sa" with each histogram of the samples c1, c2, c3, c4, c5, this through the correlation matrix.

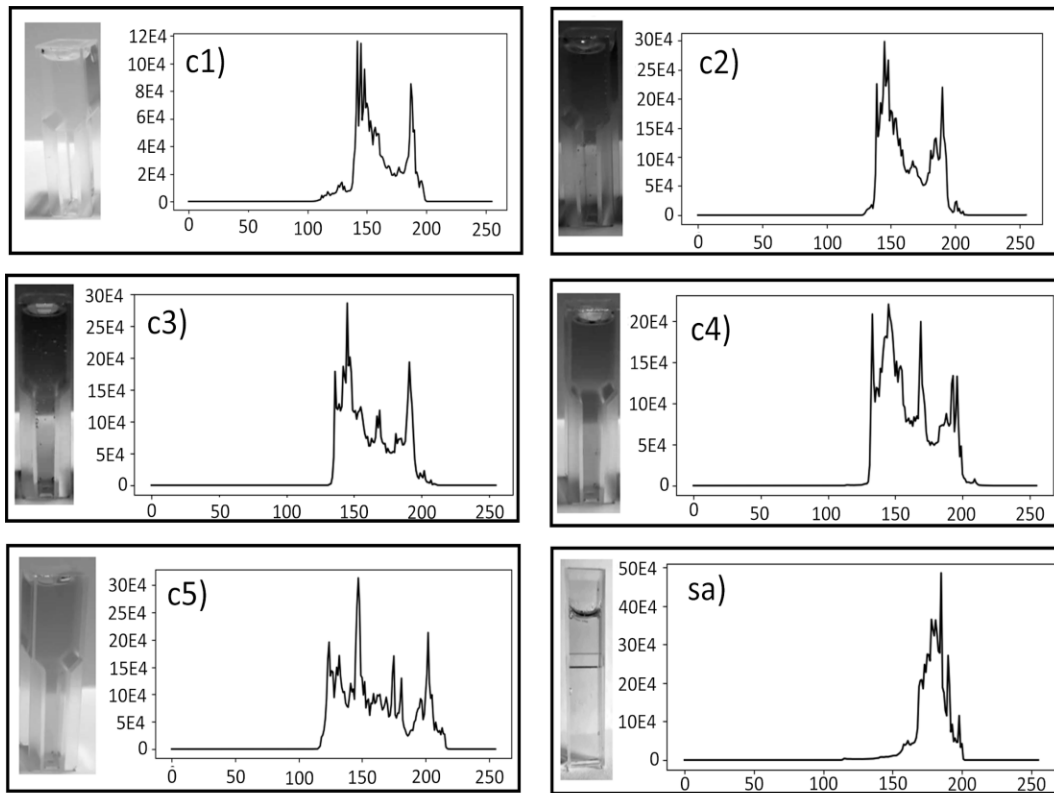

**Figure 8.** Histograms associated with each sample c1, c2, c3, c4, c5 and "sa".

Once it has been identified with which histogram has the greatest correlation, the range of concentration in honey can be associated. The correlation matrix is shown in Table 3. Sample "sa" has a higher correlation with sample c4, with a value of 0.89. Therefore, the honey concentration range of the "sa" sample is 75 % honey-25 % H<sub>2</sub>O, and it is possible to say that the sample is adulterated.

**Table 3.** Correlation matrix of samples c1, c2, c3, c4, c5 and sa.

	C1	C2	C3	C4	C5	sa
C1	1	0.85	0.81	0.82	0.79	0.67
C2	0.85	1	0.97	0.94	0.81	0.82
C3	0.81	0.97	1	0.96	0.82	0.86
C4	0.82	0.94	0.96	1	0.87	0.89
C5	0.79	0.81	0.82	0.87	1	0.8
sa	0.67	0.82	0.86	0.89	0.8	1

Through the electronic device based on Arduino and the Python-OpenCv computational tool, it was found that the

sample from the rural region has a percentage of 75% Honey - 25 H<sub>2</sub>O, that is, it has a certain degree of adulteration.

#### 4 Conclusions

The Arduino-based electronic device paired with the Python-Open computational tool emerges as an optimal solution for addressing adulteration concerns in rural areas due to its speed, affordability, and user-friendly nature. In regions lacking standardized methods for detecting honey adulteration, these tools offer a promising initial step towards resolution. Notably, our investigation identified "sa" samples from rural locales as exhibiting notable adulteration. Contrastingly, metropolitan areas face escalating challenges with increasingly intricate honey adulteration techniques, rendering conventional detection methods insufficient. The pivotal contribution of this study lies in the development of two cost-effective, user-friendly tools tailored for rural honey

characterization. Such tools fill a critical gap in regions devoid of sophisticated laboratory facilities and financial means for conventional analyses. Moreover, our methodology offers straightforward replication potential for rural residents. Remarkably, the combined cost of these tools is a mere fraction of traditional commercial equipment, underscoring their accessibility and practicality for widespread implementation.

### Acknowledgment

A deep gratitude is made to Bricia Alvarado-Acosta and Halia López-Álvarez for the technical support to carry out this work.

### 5 References

1. Frew, R., McComb, K., Croud, L., Clark, D. and Van, H. (2013). "Modified sugar adulteration test applied to New Zealand honey". *Food Chemistry* 141, 4127–4131. <http://dx.doi.org/10.1016/j.foodchem.2013.06.124>
2. Elke A (1998). "A review of the analytical methods to determine the geographical and botanical origin of honey". *Food Chemistry* 63, 549-562. [https://doi.org/10.1016/S0308-8146\(98\)00057-0](https://doi.org/10.1016/S0308-8146(98)00057-0)
3. Batista, J., Leite, E., Marques, G., Toledo, M., Gullón, B., Pintadod, M. and Magnani, M. (2016). "Sugar profile, physicochemical and sensory aspects of monofloral honeys produced by different stingless bee species in Brazilian semi-arid region". *Food Science and Technology* 65, 645-651. <https://doi.org/10.1016/j.lwt.2015.08.058>
4. Soares, S., Amaral, J., Oliveira, M. and Mafra, I. (2017). "A Comprehensive Review on the Main Honey Authentication Issues: Production and Origin". *Comprehensive Reviews in Food Science and Food Safety*. <https://doi.org/10.1111/1541-4337.12278>
5. Blasa, M, Candiracci, M., Accorsi, A., Piera, M. and Millefiori, R. (2006). "Honey is packed full of antioxidants". *Food Chemistry* 97, 217–222. <https://doi.org/10.1016/j.foodchem.2013.06.124>
6. Postmes, T. and Van Den, B. (1993). "Honey for wounds, ulcers, and skin graft preservation". *Letters to the Editor*. 341, 756-757. [https://doi.org/10.1016/0140-6736\(93\)90527-N](https://doi.org/10.1016/0140-6736(93)90527-N)
7. Weston, R. (2000). "The contribution of catalase and other natural products to the antibacterial activity of honey: a review". *Food Chemistry* 71, 235-239. [https://doi.org/10.1016/S0308-8146\(00\)00162-X](https://doi.org/10.1016/S0308-8146(00)00162-X)
8. Zábrowská, B. and Vorlová, L. (2014). "Adulteration of honey and available methods for detection – a review". *Acta Vet. Brno* 83 85-102. <https://doi.org/10.2754/avb201483S10S85>
9. Bogdanov, S., Ruoff, K. and Persano, L. (2004). "Physico-chemical methods for the characterization of unifloral honeys: a review". *Apidologie* 35, <https://doi.org/10.1051/apido:2004047>
10. Guler, A., Bakan, C., Nisbet, O. (2007). "Determination of important biochemical properties of honey to discriminate pure and adulterated honey with sucrose (*Saccharum officinarum* L.) syrup". *Food Chemistry* 105, 1119-1125. <https://doi.org/10.1016/j.foodchem.2007.02.024>

11. Bertelli, D., Lolli, M., Papotti, G., Bortolotti, L., Serra, G. and Plessi, M. (2010). "Detection of Honey Adulteration by Sugar Syrups Using One-Dimensional and Two-Dimensional High-Resolution Nuclear Magnetic Resonance". *J. Agric. Food Chem* 58, 8495–8501. <https://doi.org/10.1021/jf101460t>
12. Naila, A., Flint, S., Sulaiman, A., Ajit, A. and Weed, Z. (2018). "Classical and novel approaches to the analysis of honey and detection of adulterants". 90, 152-165. <https://doi.org/10.1016/j.foodcont.2018.02.027>
13. Codex Alimentarius. (2001). Codex standard for honey CODEX STAN 12-1981 (pp. 8). Rome, Italy: Codex Alimentarius Commission FAO/WHO.
14. Doner, W. and White, W. (1977). "Carbon-13/Carbon-12 ratio is relatively uniform among honeys". *Science* 197, 891-892. <https://doi.org/10.1126/science.197.4306.891>
15. Kaskoniene, V. (2010). "Floral Markers in Honey of Various Botanical and Geographic Origins: A Review". *Comprehensive Reviews in Food Science and Food Safety* 9, 620-634. <https://doi.org/10.1111/j.1541-4337.2010.00130.x>
16. Hida, N., Bidin, N., Abdullah, M., Yasin, M. (2013). "Fiber optic displacement sensor for honey purity detection in distilled water". *Optoelectronics and Advanced Materials – rapid communications* 7, 565 - 568.
17. Cruz-Domínguez, O., Guirette-Barbosa, O., Carrera-Escobedo, J., Duran-Muñoz, H., Guzman-Valdivia, C., Ruelas-Santoyo, E. (2021). "Use of partial quality function deployment to identify processes required for iso 9001". *The South African Journal of Industrial Engineering* 32. <https://doi.org/10.7166/32-2-2415>
18. Guzmán-Fernández, M., Zambrano de la Torre, M., Ortega-Sigala, J., Durán-Muñoz, H. (2021). "Arduino: a Novel Solution to the Problem of High-Cost Experimental Equipment in Higher Education". *Exp Tech* 45, 613–625. <https://doi.org/10.1007/s40799-021-00449-1>
19. Gordon, J. and Harman, S. (2002). "A Graduated Cylinder Colorimeter: An Investigation of Path Length and the Beer-Lambert Law". *J. Chem. Educ.* 79. <https://doi.org/10.1021/ed079p611>